



Technical Data Sheet

Theta 40



Theta 40 Series of multi-transducers simultaneously measure several variables of an electric power system and process them to produce 2 or 3 or 4 analogue output signals. 2 or 4 digital outputs are available for signaling limits or power metering. For two of the limit outputs up to 3 measurands can be logically combined.

Special Features

- For all heavy-current power system variables
- Up to 6 outputs (2A + 4D or 4A + 2D or 2A or 3A)
- Input voltage up to 693 V (phase-to-phase)
- Universal analogue outputs (programmable)
- High accuracy: U/I 0.2%, Frequency 0.15% and P 0.25% (under reference conditions)
- Universal digital outputs (meter transmitter, limits)
- AC/DC power supply/universal (24-80V AC/DC or 85-230V AC/DC)
- Windows software with password protection for programming, data analysis, power system status simulation, acquisition of meter data and making settings

Application

Theta 40 for the measurement of electrical variables in heavy current power systems

The Theta Series series of multi-transducers **simultaneously** measure several variables of an electric power system and process them to produce 2 or 3 or 4 analogue output signals. 2 or 4 digital outputs are available for signaling limits or power metering. For two of the limit outputs up to 3 measurands can be logically combined.

The multi - transducers are also equipped with an serial **RS 232** interface to which a PC with the corresponding software can be connected for programming or accessing & executing useful ancillary functions. The usual modes of connection, the types of measured variables, their ratings, the transfer characteristic for each output etc. are the main parameters that have to be programmed.

Ancillary functions include a power system check, provision for displaying the measured variable on a PC monitor, the simulation of the outputs for test purposes and a facility for printing nameplates.

Table 1

Measured variables	Output	Types
Current, voltage (rms), active/reactive/ apparent power cos, sin, power factor RMS value of the current with wire setting range (bimetal measuring function)	2 analogue outputs	Theta M20
	3 analogue outputs	Theta M30
Slave pointer function for the measurement of the RMS value IB Frequency	2 analogue outputs and 4 digital outputs or 4 analogue outputs and 2 digital outputs	Theta M24
		Theta M42
Average value of the currents with sign of the active power (power system only)	4 analogue outputs and bus RS 485 (MODBUS)	Theta M40 *
	Data bus (LON) M00	Theta M00 *
	Bus RS 485 (MODBUS)	Theta M01 *
	4 analog output with RS 485, optional display	Theta Trans *

* Refer dedicated data sheet for complete product details.

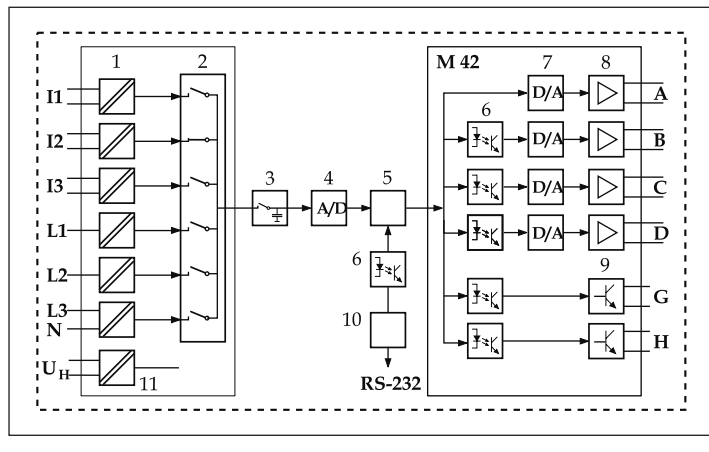

- 1 = Input transformer
- 2 = Multiplexer
- 3 = Latching stage
- 4 = A/D converter
- 5 = Microprocessor
- 6 = Electrical insulation
- 7 = D/A converter
- 8 = Output amplifier/latching stage
- 9 = Digital output (open-collector)
- 10 = Programming interface RS-232
- 11 = Power supply

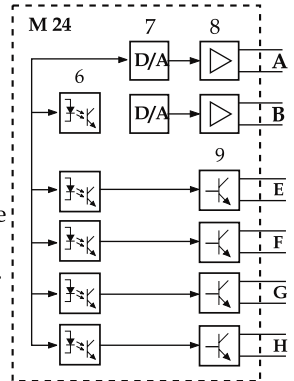

Fig. 2. Block diagram.

Table 2 A, B, C, D = analogue outputs; E, F, G, H = digital outputs.

Models	Analog Output	Digital Output	Communication type	Programming Port
Theta M42	4(A,B,C,D)	(E,F)	-	RS 232
Theta M24	2(A,B)	(E,F,G,H)	-	RS 232
Theta M20	2(A,B)	-	-	RS 232
Theta M30	3(A,B,C)	-	-	RS 232
Theta M00	-	-	LON Bus	RS 232
Theta M40	4(A,B,C,D)	-	RS 485	RS 232
Theta M01	-	-	RS 485	RS 232
ThetaTrans	4(A,B,C,D)	-	RS 485	RS 232

Table 3 : Symbols and their meaning

Symbols	Meaning
X	Measured variable
X0	Lower limit of the measured variable
X1	Break point of the measured variable
X2	Upper limit of the measured variable
Y	Output variable
Y0	Lower limit of the output variable
Y1	Break point of the output variable
Y2	Upper limit of the output variable
U	Input voltage
Ur	Rated value of the input voltage

Table 3 : Symbols and their meaning

Symbols	Meaning	Symbols	Meaning
U 12	Phase-to-phase voltage L1 - L2	Q3	Reactive power phase 3 (phase-to-neutral L3-N)
U 23	Phase-to-phase voltage L2 - L3	S	Apparent power of the system $S = \sqrt{I_1^2 + I_2^2 + I_3^2} \cdot \sqrt{U_1^2 + U_2^2 + U_3^2}$
U 31	Phase-to-phase voltage L3 - L1	S1	Apparent power phase 1 (phase-to-neutral L1-N)
U1N	Phase-to-neutral voltage L1 - N	S2	Apparent power phase 2 (phase-to-neutral L2-N)
U2N	Phase-to-neutral voltage L2 - N	S3	Apparent power phase 3 (phase-to-neutral L3-N)
U3N	Phase-to-neutral voltage L3 - N	Sr	Rated value of the apparent power of the system
UM	Average value of the voltages (U1N + U2N + U3N) / 3	PF	Active power factor $\cos \varphi = P/S$
I	Input current	PF1	Active power factor phase1 P1/S1
I1	AC current L1	PF2	Active power factor phase2 P2/S2
I2	AC current L2	PF3	Active power factor phase3 P3/S3
I3	AC current L3	QF	Reactive power factor $\sin j = Q/S$
Ir	Rated value of the input current	QF1	Reactive power factor phase1 Q1/S1
IM	Average value of the currents (I1+ I2 + I3) / 3	QF2	Reactive power factor phase2 Q2/S2
IMS	Average value of the currents and sign of the active power (P)	QF3	Reactive power factor phase3 Q3/S3
IB	RMS value of the current with wire setting range (bimetal measuring function)	LF	Power factor of the system $LF = \text{sgn}Q (1 - PF)$
IBT	Response time for IB	LF1	Power factor phase 1 $\text{sgn}Q1 (1 - PF1)$
BS	Slave pointer function for the measurement of the RMS value IB	LF2	Power factor phase 2 $\text{sgn}Q2 (1 - PF2)$
BST	Response time for BS	LF3	Power factor phase 3 $\text{sgn}Q3 (1 - PF3)$
φ	Phase-shift between current and voltage	c	Factor for the intrinsic error
F	Frequency of the input variable	R	Output load
Fn	Rated frequency	Rn	Rated burden
P	Active power of the system $P = P1 + P2 + P3$	H	Power supply
P1	Active power phase 1 (phase-to-neutral L1 - N)	Hn	Rated value of the power supply
P2	Active power phase 2 (phase-to-neutral L2 - N)	CT	c.t. ratio
P3	Active power phase 3 (phase-to-neutral L3 - N)	VT	v.t. ratio
Q	Reactive power of the system $Q = Q1 + Q2 + Q3$		
Q1	Reactive power phase 1 (phase-to-neutral L1-N)		
Q2	Reactive power phase 2 (phase-to-neutral L2-N)		

Technical data

Reference conditions	
Ambient temperature	+ 23 °C ± 1 K
Pre-conditioning	30 min. acc. to DIN EN 60 688 Section 4.3, Table 2
Input variable	Rated useful range
Power supply	H = H _n + 1%
Active/reactive factor	cosφ=1 resp. sin φ = 1
Frequency	50 ... 60 Hz, 16 2/3 Hz
Waveform	Sinusoidal, form factor 1.1107
Output load	DC current output: $R_n = \frac{7.5 \text{ V}}{Y_2} \pm 1\%$ DC voltage output: $R_n = \frac{Y_2}{1 \text{ mA}} \pm 1\%$
Miscellaneous	DIN EN 60 688

* Basic accuracy 0.5 c for applications with phase-shift

Duration of the measurement cycle	Approx. 0.25 to 0.5 s at 50 Hz, depending on measured variable & programming
Response time	1 ... 2 times the measurement cycle
Factor c (the highest value applies)	
Linear characteristic	$c = \frac{1 - \frac{Y_0}{Y_2}}{1 - \frac{X_0}{X_2}}$ or $c = 1$
Bent characteristic X ₀ ≤ X ≤ X ₁	$c = \frac{Y_1 - Y_2}{X_1 - X_2} \cdot \frac{X_2}{Y_2}$ or $c = 1$
X ₁ ≤ X ≤ X ₂	$c = \frac{1 - \frac{Y_1}{Y_2}}{1 - \frac{X_1}{X_2}}$ or $c = 1$

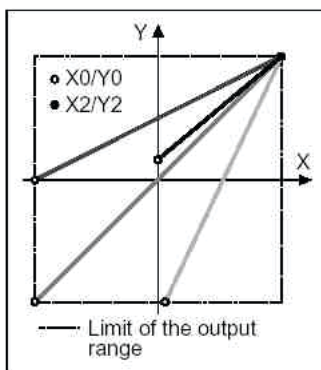

Fig. 3. Examples of settings with linear characteristic.

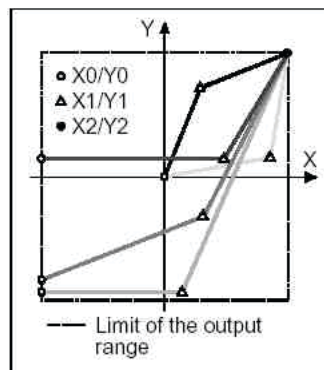

Fig. 4. Examples of settings with bent characteristic.

Power Supply →

AC voltage	100, 110, 230, 400, 500 or 693 V, + 10%, 45 to 65 Hz Power consumption approx. 10 VA
AC/DC power pack (DC and 50 ... 60 Hz)	

Input →	
Input variables	see Table 10 (Page 6) and 15 (Page 11)
Measuring ranges	see Table 10 (Page 6) and 15 (Page 11)
Waveform	Sinusoidal
Rated frequency	50...60 Hz; 16 2/3 Hz
Own consumption	Voltage circuit: ≤U ² / 400 kW Condition: external power supply Current circuit: 0.3 VA I/5 A

Table 5 : Continuous thermal ratings of inputs

Current circuit	10 A 400 V single-phase AC system 693 V three-phase system
Voltage circuit	480V single-phase AC system 831V three-phase system

Table 6 : Short-time thermal rating of inputs

Input variable	Number of inputs	Duration of overload	Interval between two overloads
Current circuit		400 V single-phase AC system 693 V three-phase system	
100 A	5	3 s	5 min.
250 A	1	1 s	1 hour
Voltage circuit		1 A, 2 A, 5 A	
Single-phase AC system 600 V H _{intern} : 1.5 Ur	10	10 s	10 s.
Three-phase system 1040 V H _{intern} : 1.5 Ur	10	10 s	10 s.

Programming connector on transducer

Interface	RS 232 C
DSUB socket	9-pin
	The interface is electrically insulated from all other circuits

Influencing quantities and permissible variations

Acc. to DIN IEC 688

Technical data

Table 7 : Analogue output \rightarrow

Output variable Y	Impressed DC current	Impressed DC voltage
Full scale Y2	see "Ordering information"	see "Ordering information"
Limits of output signal for input overload and/or	see "Ordering information"	see "Ordering information"
R=0	1.25 Y2	40 mA
R \rightarrow ∞	30V	1.25 Y2
Rated useful range of output load	$0 \leq \frac{7.5 V}{Y2} \leq \frac{15 V}{Y2}$	$\frac{Y2}{2 mA} \leq \frac{Y2}{1 mA} \leq \infty$
AC component of output signal (peak-to-peak)	$\leq 0.005 Y2$	$\leq 0.005 Y2$

The outputs A, B, C and D may be either short or open-circuited. They are electrically insulated from each other and from all other circuits (floating)

All the full - scale output values can be reduced subsequently using the programming software, but a supplementary error results. The hardware full-scale settings for the analogue outputs may also be changed subsequently. Conversion of a current to a voltage output or vice versa is also possible. This necessitates changing resistors on the output board. The full-scale values of the current and voltage outputs are set by varying the effective value of two parallel resistors (better resolution). The values of the resistors are selected to achieve the minimum absolute error. Calibration with the programming software is always necessary following conversion of the outputs. Refer to the Operating Instructions.

Caution : The warranty is void if the device is tampered.

Digital outputs, pulse outputs, limit outputs \rightarrow

The digital outputs conform to DIN43 864. The pulse width can be neither programmed nor is there a hardware setting.

Type of contact	Open collector
Number of pulses	see "Ordering information"
Pulse duration	≥ 100 ms
Interval	≥ 100 ms
Power supply	8 ... 40 V
Output current	ON 10 ... 27 mA QFF < 2 mA

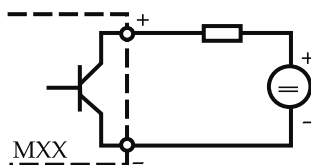

System response
Accuracy class

(the reference value is the fullscale value Y2)

Table 8

Measured variable	Condition	Accuracy class*
System Active, reactive and apparent power	$0.5 \leq X2/Sr \leq 1.5$	0.25 c
	$0.3 \leq X2/Sr < 0.5$	0.5 c
Phase Active, reactive and apparent power	$0.167 \leq X2/Sr \leq 0.5$	0.25 c
	$0.1 \leq X2/Sr < 0.167$	0.5 c
Power factor, active power and reactive power	$0.5Sr \leq S \leq 1.5 Sr, (X2 - X0) = 2$	0.25 c
	$0.5Sr \leq S \leq 1.5 Sr, 1 \leq (X2 - X0) < 2$	0.5 c
	$0.5Sr \leq S \leq 1.5 Sr, 0.5 \leq (X2 - X0) < 1$	1.0 c
	$0.1Sr \leq S < 0.5 Sr, (X2 - X0) = 2$	0.5 c
	$0.1Sr \leq S < 0.5Sr, 1 \leq (X2 - X0) < 2$	1.0 c
	$0.1Sr \leq S < 0.5Sr, 0.5 \leq (X2 - X0) < 1$	2.0 c
AC Voltage	$0.1 Ur \leq U \leq 1.2 Ur$	0.2 c
AC current/ current averages	$0.1 Ir \leq I \leq 1.5 Ir$	0.2 c
System frequency	$0.1 Ur \leq U \leq 1.2 Ur$ resp. $0.1 Ir \leq I \leq 1.5 Ir$	0.15+ 0.03 c ($f_N = 50 \dots 60$ Hz)
		0.15 + 0.1 c ($f_N = 16 \frac{2}{3}$ Hz)
Pulse	acc. to IEC 1036 $0.1 Ir \leq I \leq 1.5 Ir$	1.0 c

Ambient conditions

Climatic rating	Climate class 3 acc. to VDI/VDE3540
Variations due to ambient temperature	$\pm 0.1\%$ / 10 K
Nominal range of use for temperature	0...15...30...45 °C (usage group II)
Storage temperature	- 40 to + 85 °C
Annual mean relative humidity	$\leq 75\%$

Table 9: Rated voltages and tolerances

Rated voltage U_N	Tolerance
24 ... 60 V DC/AC	DC -15 ... + 33%
85 ... 230 V DC/AC	AC $\pm 10\%$
Consumption:	≤ 9 W resp. ≤ 10 VA

Applicable standards and regulations

Table 4	
DIN EN 60 688	Electrical measuring transducers for converting AC electrical variables into analogue and digital signals
IEC 1010 or EN 61 010	Safety regulations for electrical measuring, control and laboratory equipment
EN 60529	Protection types by case (code IP)
IEC 255-4 Part E5	High-frequency interference test (solid-state relays only)
IEC 1000-4-2,3,4,6	Electromagnetic compatibility for industrial process measurement & control equipment
VDI/VDE 3540, page2	Reliability of measuring and control equipment (classification of climates)
DIN 40 110	AC quantities
DIN 43 807	Terminal markings
IEC 68 /2-6	Basic environmental testing procedures, vibration, sinusoidal
IEC 1036	Solid state AC watt hour meters for active power (Classes 1 and 2)
DIN 43864	Current interface for the transmission of impulses between impulse encoder counter and tariff meter
UL 94	Tests for flammability of plastic materials for parts in devices and appliances

Safety	
Protection class	II
Enclosure protection	IP 40, housing IP 20, terminals
Overvoltage category	III
Insulation test (versus earth)	Input voltage : AC 400 V Input current : AC 400 V Output : DC 40 V Power supply : AC 400 V DC 230 V
Surge test	5 KV; 1.2/50 ms; 0.5 Ws
Test voltages	50 Hz, 1 Min. according to DIN EN 61 010-1 5550 V, inputs versus all other circuits as well as outer surface 3250 V, input circuits versus each other 3700 V, power supply versus outputs and SCI as well as outer surface 490 V, outputs and SCI versus each other and versus outer surface

Vibration withstand	
(tested according to DIN EN 60 068-2-6) Acceleration	± 2 g
Frequency range	10...150 10 Hz, rate of frequency sweep: 1 octave/minute
Number of cycles	10 in each of the three axes
Result	No faults occurred, no loss of accuracy and no problems with the snap fastener

Installation data	
Housing	HousingT24 See Section "Dimensioned drawings"
Housing material	Lexan 940 (polycarbonate), flammability class V-0 acc. to UL 94, self-extinguishing, non-dripping, free of halogen
Mounting	For snapping onto top-hat rail (35X15 mm or 35X7.5 mm) acc. to EN 50 022 or directly onto a wall or panel using the pull-out screw hole brackets
Orientation	Any
Weight	With supply transformer approx. 1.1 kg With AC/DC power pack approx. 0.7 kg

Terminals	
Type	Screw terminals with wire guards
Max. wire gauge	≤ 4.0 mm ² single wire or 2 X 2.5 mm ² fine wire (use Taparia Screw driver-type 902) To use flat head lugs with total metal length (J) greater than or equal to 17mm.
Lugs	Lug 

Table 10 : Theta 40, standard version

The two versions of the transducer below with the **basic** programming are available AC Aux. & AC/DCAux.

Description / Basic programming		M 42	M 24	M20	M30	M40	M00	M01	Theta Trans
Mechanical design: Rated frequency:	Housing T24 for rail and wall mounting 50 Hz (60 Hz admissible without additional error, re-programming by user for 16 2/3Hz possible, but with additional error 1.25 c)				<input type="checkbox"/> <input type="checkbox"/>	<input type="checkbox"/> <input type="checkbox"/>			
Power supply:	230 VAC 85...230 V DC/AC				<input type="checkbox"/> <input type="checkbox"/>	<input type="checkbox"/> <input type="checkbox"/>			
Power supply:	External connection (standard)	<input type="checkbox"/>	<input type="checkbox"/>	<input type="checkbox"/>	<input type="checkbox"/>	<input type="checkbox"/>	<input type="checkbox"/>	<input type="checkbox"/>	<input type="checkbox"/>
Full-scale output signal, output A:	Y2 = 20 mA	<input type="checkbox"/>	<input type="checkbox"/>	<input type="checkbox"/>	<input type="checkbox"/>	<input type="checkbox"/>	N. A.	N. A.	<input type="checkbox"/>
Full-scale output signal, output B:	Y2 = 20 mA	<input type="checkbox"/>	<input type="checkbox"/>	<input type="checkbox"/>	<input type="checkbox"/>	<input type="checkbox"/>	N. A.	N. A.	<input type="checkbox"/>
Full-scale output signal, output C:	Y2 = 20 mA	<input type="checkbox"/>	N. A.	N. A.	N. A.	<input type="checkbox"/>	N. A.	N. A.	<input type="checkbox"/>
Full-scale output signal, output D:	Y2 = 20 mA	<input type="checkbox"/>	N. A.	N. A.	N. A.	<input type="checkbox"/>	N. A.	N. A.	<input type="checkbox"/>
Test certificate:	None supplied	<input type="checkbox"/>	<input type="checkbox"/>	<input type="checkbox"/>	<input type="checkbox"/>	<input type="checkbox"/>	<input type="checkbox"/>	<input type="checkbox"/>	<input type="checkbox"/>
Programming:	Basic	<input type="checkbox"/>	<input type="checkbox"/>	<input type="checkbox"/>	<input type="checkbox"/>	<input type="checkbox"/>	<input type="checkbox"/>	<input type="checkbox"/>	<input type="checkbox"/>
Optional Display:		<input type="checkbox"/>	<input type="checkbox"/>	<input type="checkbox"/>	<input type="checkbox"/>	<input type="checkbox"/>	<input type="checkbox"/>	<input type="checkbox"/>	<input type="checkbox"/>
See Table 15 : "Ordering information for MXX models" Theta Series		N. A.	N. A.	N. A.	N. A.	N. A.	N. A.	N. A.	<input type="checkbox"/>
Basic programming									
Application	4-wire,3-phase system, asymmetric load(NPS)				<input type="checkbox"/>				
Input voltage	Design value Ur = 400 V				<input type="checkbox"/>				
Input current	Design value Ir = 5 A without specification of primary ratings				<input type="checkbox"/>				
Measured variable, output A Output signal, output A	P1; X0= 115.47 W; X2 = 115.47 W # DC current Y0 = - 20 mA; Y2 = 20 mA Linear characteristic Standard limits	<input type="checkbox"/>	<input type="checkbox"/>	<input type="checkbox"/>	<input type="checkbox"/>	<input type="checkbox"/>	N. A.	N. A.	<input type="checkbox"/>
Measured variable, output B Output signal, output B	P2; X0 = - 115.47; X2 = 115.47 W # DC current Y0 = - 20 mA; Y2 = 20 mA Linear characteristic Standard limits	<input type="checkbox"/>	<input type="checkbox"/>	<input type="checkbox"/>	<input type="checkbox"/>	<input type="checkbox"/>	N. A.	N. A.	<input type="checkbox"/>
Measured variable, output C Output signal, output C	P3; X0 = 115.47 W; X2 = 115.47 W # DC current Y0 = - 20 mA; Y2 = 20 mA Linear characteristic Standard limits	<input type="checkbox"/>	N. A.	N. A.	<input type="checkbox"/>	<input type="checkbox"/>	N. A.	N. A.	<input type="checkbox"/>
Measured variable, output D Output signal, output D	P; X0 = - 346.41; X2 = 346.41 W# DC current Y0 = - 20 mA; Y2 = 20 mA Linear characteristic Standard limits	<input type="checkbox"/>	N. A.	N. A.	N. A.	<input type="checkbox"/>	N. A.	N. A.	<input type="checkbox"/>
Output signal, output E	Limit P; XI = 311.77 W # Output ON if X>XI Min. pick-up delay	N. A.	<input type="checkbox"/>	N. A.	N. A.	N. A.	N. A.	N. A.	N. A.
Output signal, output F	Limit Q; XI= 34.64 var # Output ON if X>XI Min. pick-up delay	N. A.	<input type="checkbox"/>	N. A.	N. A.	N. A.	N. A.	N. A.	N. A.
Measured variable, output G	Limit P1; XI= 115.47 W # Output ON if X> XI Min. pick-up delay	<input type="checkbox"/>	<input type="checkbox"/>	N. A.	N. A.	N. A.	N. A.	N. A.	N. A.
Measured variable, output H	Limit I1; XI = 2 A # Output ON if X> X1 Min. pick-up delay	<input type="checkbox"/>	<input type="checkbox"/>	N. A.	N. A.	N. A.	N. A.	N. A.	N. A.

Other specifications on request contact to Factory

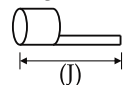
Electrical Connections

Table 11

Function		Connection		
Meas. input AC current	IL1	1 / 3		
	IL2	4 / 6		
	IL3	7 / 9		
Meas. input AC Voltage	UL1	2		
	UL2	5		
	UL3	8		
	N	11		
Outputs	Analogue →○	Digital + - + - + - + - + - + -	A	15
			B	16
			C	17
			D	18
			E	19
			F	20
	→○	G	21	
		H	22	
		I	23	
		J	24	
		K	25	
		L	26	
Power Supply AC	~	13		
	~	14		
	+	13		
	-	14		

If power supply is taken from the measured voltage internal connections are as follow:

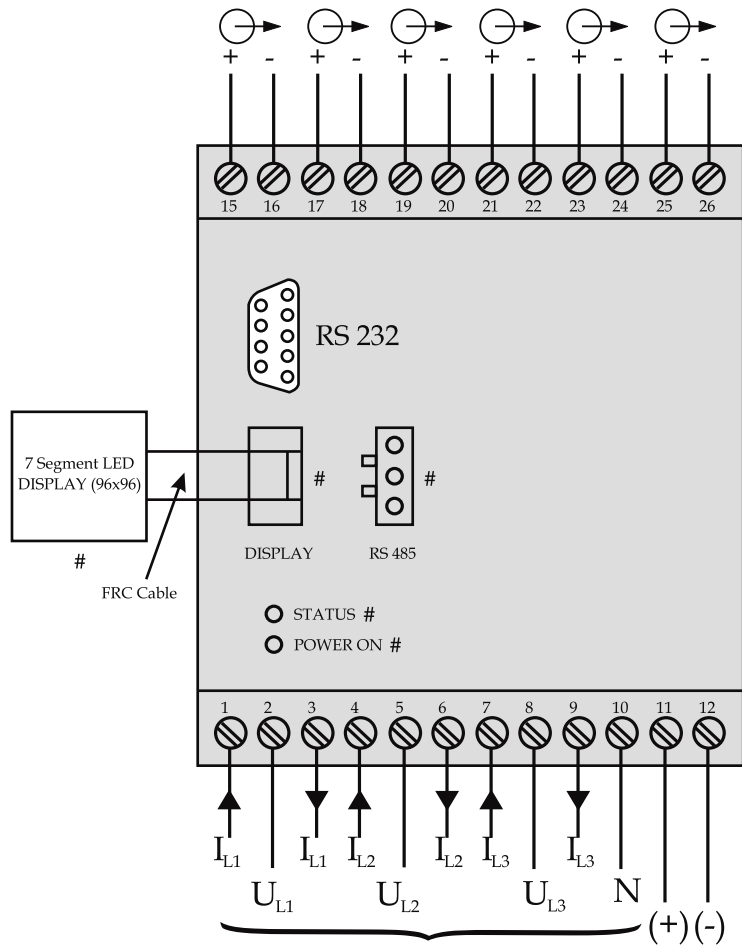

Table 12

Application (system)	Internal connection Terminal / System
Single phase AC current	2 / 11 (L1 - N)
4-wire 3-phase symmetric load	2 / 11 (L1 - N)
All other *	2 / 5 (L1 - L2)

Table 13

	Modbus
M40	23, 24, 25, 26 (RS 485)
M00	15, 16 LON Bus
M01	23, 24, 25, 26 (RS 485)

applicable only for Theta Trans

Table 14

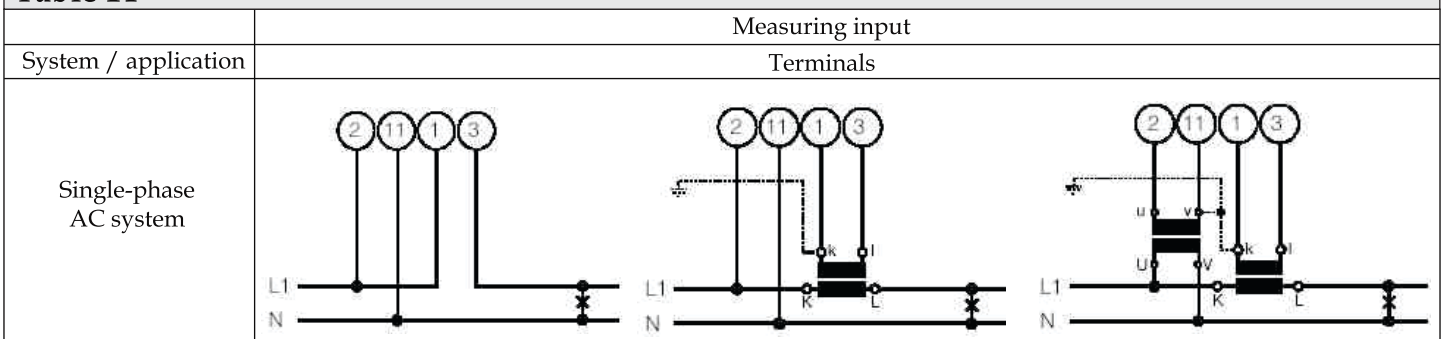

Electrical Connections

Table 14

Measuring input

System/application

Terminals

3-wire
3-phase
symmetric
load
I: L1

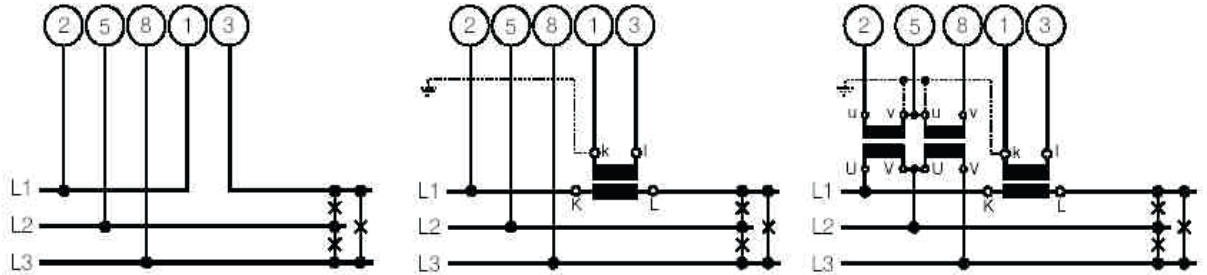

Connect the voltage according to the following table for current measurement in L2 or L3:

Current transformer	Terminals	2	5	8
L1	1 3	L2	L3	L1
L3	1 3	L3	L1	L2

3-wire
3-phase
symmetric
load
Phase-shift
U: L1 - L2
I: L1

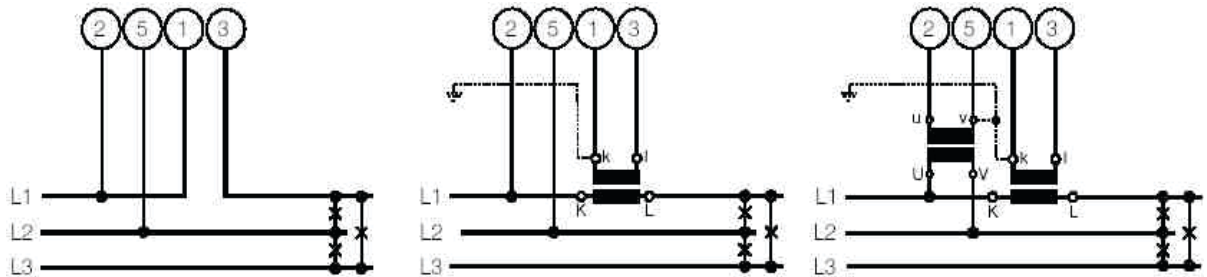

Connect the voltage according to the following table for current measurement in L2 or L3:

Current transformer	Terminals	2	5
L2	1 3	L2	L3
L3	1 3	L3	L1

3-wire
3-phase
symmetric
load
Phase-shift
U: L3 - L1
I: L1

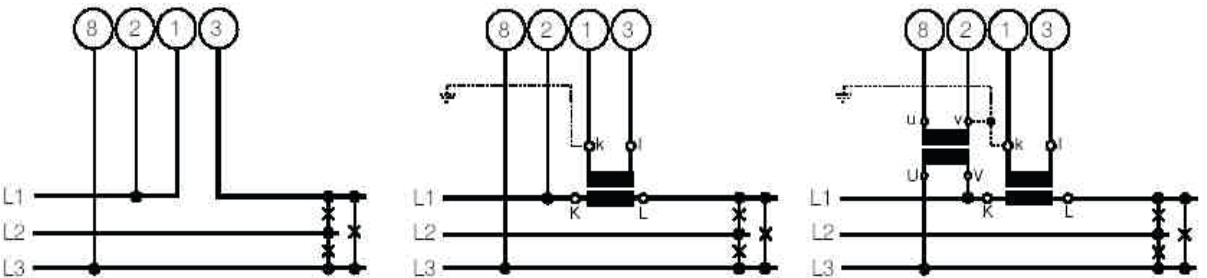

Connect the voltage according to the following table for current measurement in L2 or L3:

Current transformer	Terminals	8	2
L2	1 3	L1	L2
L3	1 3	L2	L3

Electrical Connections

Table 14

Measuring input

System/application

Terminals

3-wire
3-phase
symmetric
load
Phase-shift
U: L2 - L3
I: L1

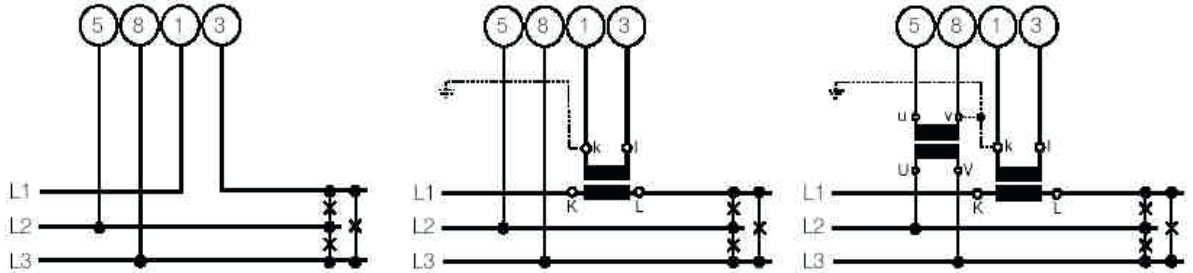

Connect the voltage according to the following table for current measurement in L2 or L3:

Current transformer	Terminals	5	8
L2	1 3	L3	L1
L3	1 3	L1	L2

4-wire
3-phase
symmetric
load
I: L1

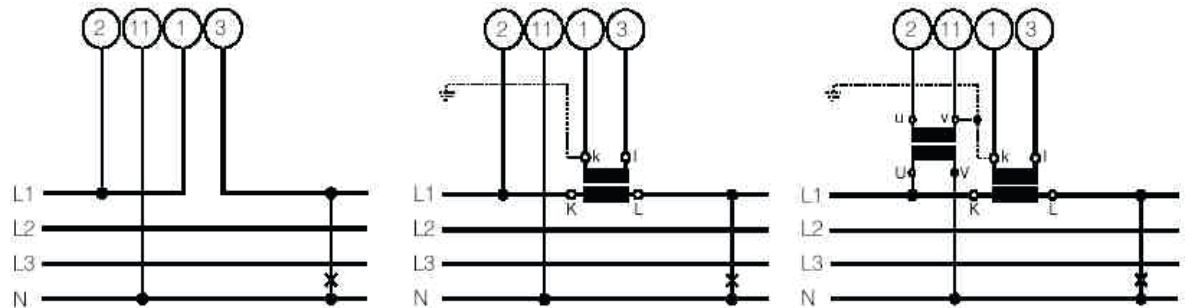

Connect the voltage according to the following table for current measurement in L2 or L3:

Current transformer	Terminals	2	11
L2	1 3	L2	N
L3	1 3	L3	N

3-phase
3-wire
asymmetric
load *

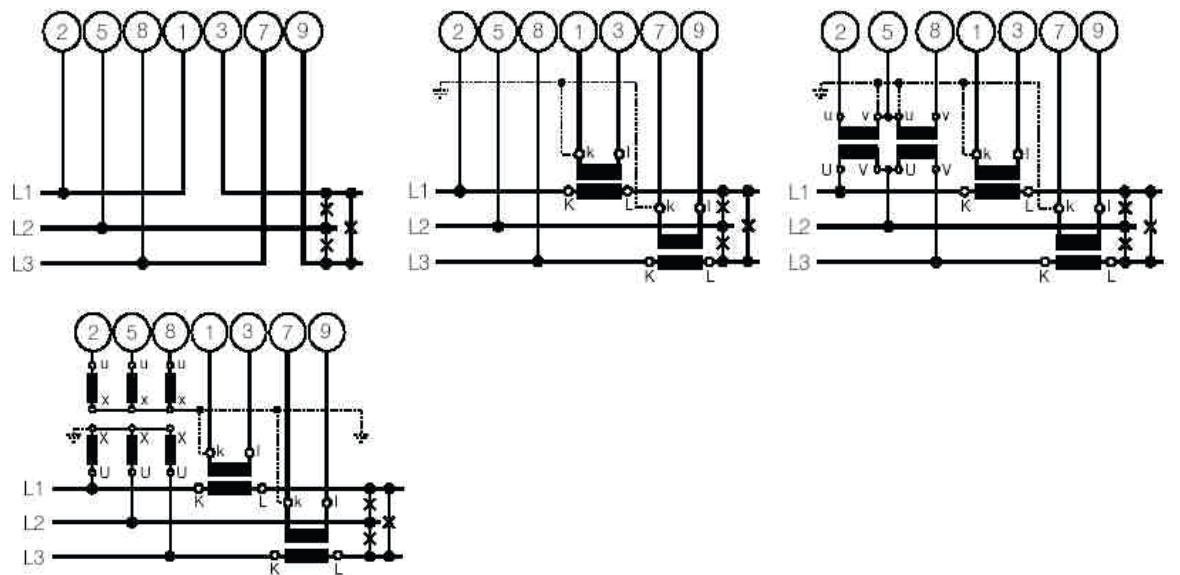

* Contact to factory for complete details

Electrical Connections

Table 14

Measuring input	
System / application	Terminals
3-phase 3-wire asymmetric load *	
	<p>3 single-pole insulated voltage transformers in high-voltage system</p>
4-wire asymmetric load, 3-phase Open Y connection*	<p>Low-voltage system</p>
	<p>2 single-pole insulated voltage transformers in high-voltage system</p>

* Contact to factory for complete details

Relationship between PF, QF and LF

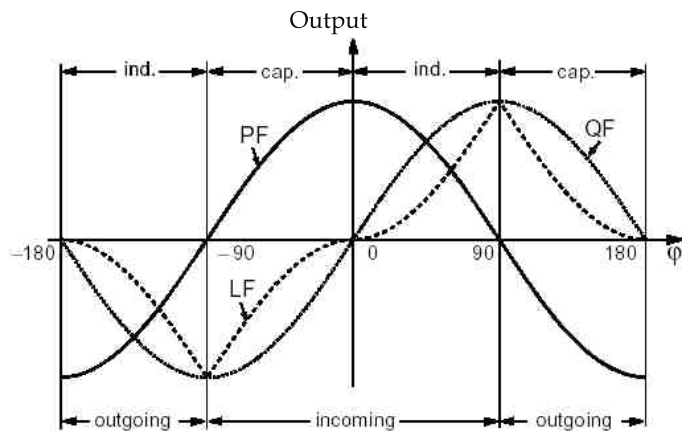

Fig. 5. Active power PF-----, reactive power QF -----, power factor LF-----.

Dimensional Drawing

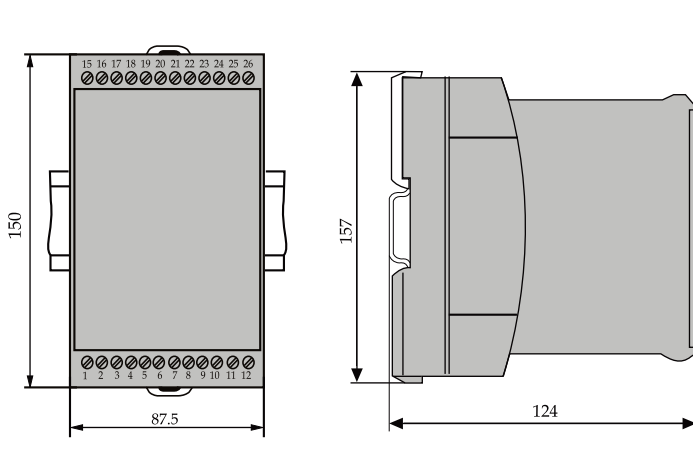

Fig. 6. Theta Series in housing T24 clipped onto a top-hat rail (35 X 15 mm or 35 X 7.5 mm, acc. to EN 50 022).

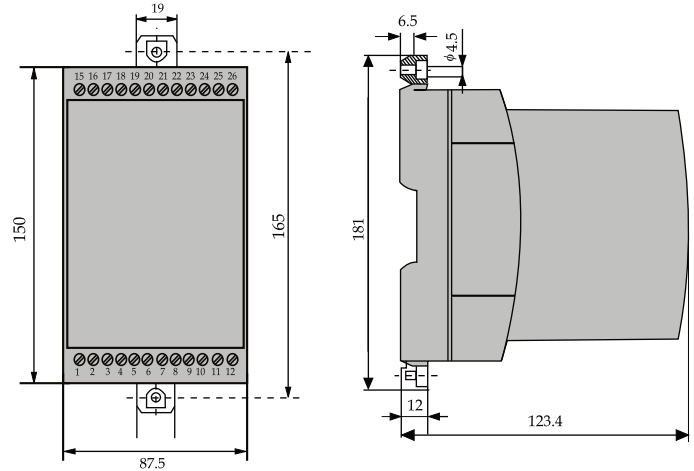

Fig. 7. Theta Series in housing T24, screw hole mounting brackets pulled out.

Ordering Information

Product Code	TT40-	X	X	0000000000
Compensation	M42	1		
	M24	2		
	M20	3		
	M40 RS485	4		
	M30	5		
	M01 RS485	6		
	M00 LONBUS	7		
Power Supply	24-60U		F	
	85-230U		J	



sifam tinsley
PRECISION INSTRUMENTATION

Manufactured by:
Sifam Tinsley Instrumentation Inc
3105 Creekside Village Dr,
Unit 801, Kennesaw GA 30144

Distributed by:
Veracious Canada Inc
1101 Britannia Rd E,
Mississauga, ON L4W 3X1
Contact: +1 416-640-5364
Fax: +1 416-981-3933
E-mail: info@veraciousinc.ca
Web: www.veraciousinc.com