

Operating Instructions

Multifunction Instrument *THETA 40*

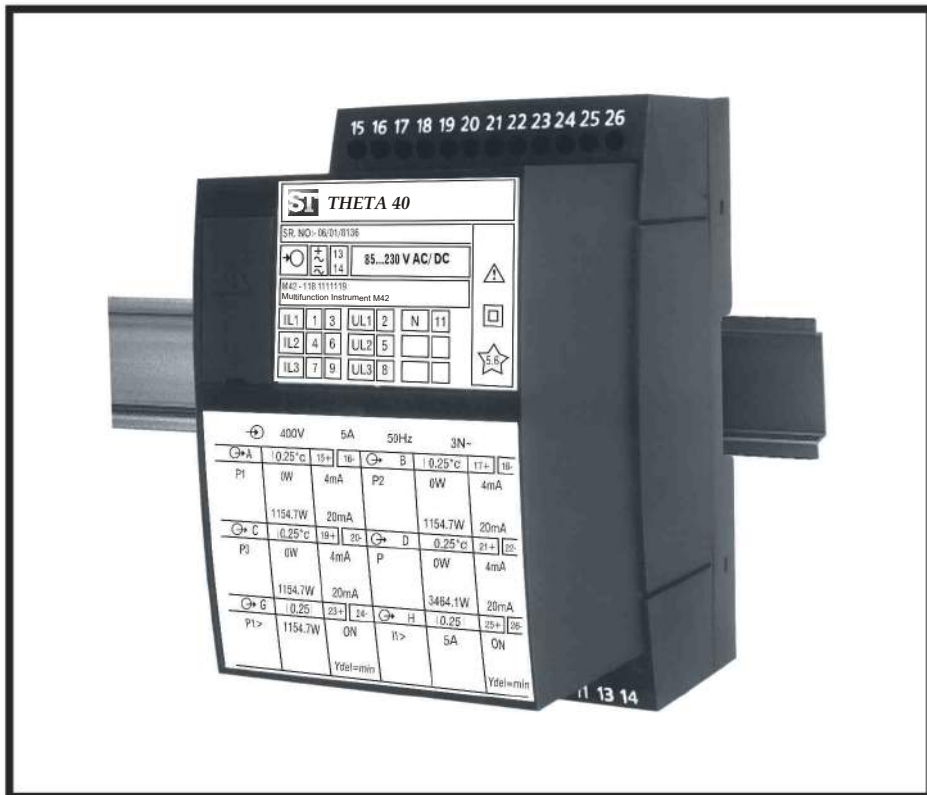

2-60-006-00-00546

Rev. A_10/2014

Operating Instructions

Programmable Multifunction Instrument *THETA 40*

Contents

1. Read first and then	2
2. Scope of supply	2
3. Brief description	2
4. Physical installation	2
4.1 Mounting on top-hat rails	2
4.2 Fastening on a mounting surface	3
5. Electrical connections	3
6. Commissioning	6
6.1 Technical data	7
6.2 Programming the transducer	9
6.3 Operation of the binary output	10
7. Withdrawing and inserting the device	10
8. Reconfiguring the analogue outputs	11
8.1 Without hardware setting change	11
8.2 With hardware setting change	11
9. Notes on Maintenance	12
10. Releasing the transducer	13
11. Dimensional drawings	13
12. Safety notes	13

1. Read first and then ...



The proper and safe operation of the device assumes that the Operating Instructions are read and the safety warnings given in the various Sections

4. Physical Installation
5. Electrical connections
6. Commissioning
12. Safety notes

are observed.

The device should only be handled by appropriately trained personnel who are familiar with it and authorised to work in electrical installations.

2. Scope of supply (Figs. 1 and 3)



Fig. 1

⊖					
⊕→A	15→	16D	⊕→B	17→	18D
⊕→E	19→	20D	⊕→F	21→	22D
⊕→G	23→	24D	⊕→M	25→	26D

Fig. 3

Transducer (Fig. 1)

1 Operating Instructions

1 blank type label (Fig. 3), for recording programmed settings

3. Brief description

The Multifunction Instrument *THETA 40* **simultaneously** measure several variables of an electric power system and process them to produce 2 resp.4 analogue output signals.

2 or 4 digital outputs are available for signalling limits or power metering. For two of the limit outputs up to three measurands can be logically combined.

The Multifunction Instruments are also equipped with **RS 232** serial interface to which a PC with the corresponding software can be connected for programming or accessing and executing useful ancillary functions.

The usual modes of connection, the types of measured variables, their ratings, the transfer characteristic for each output etc. are the main parameters that have to be programmed.

Ancillary functions include a power system check, provision for displaying the measured variable on a PC monitor, the simulation of the outputs for test purposes and a facility for printing nameplates.

4. Physical installation

The transducer can be mounted either on a top-hat rail or directly onto a wall or mounting surface.



Note "Environmental conditions" in Section "6.1 Technical data" when determining the place of installation!

4.1 Mounting on top-hat rails

Simply clip the device onto the top-hat rail (EN 50 022) (See Fig. 4)

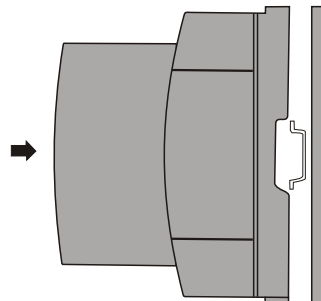

Fig. 4 Mounting on top-hat rail 35 × 15 or 35 × 7.5 mm.

4.2 Fastening on a mounting surface

While pressing the latch (4) in the base of the device (Fig. 5, left) pull out the isolating amplifier securing brackets (1). To return the brackets to their original positions, the latch (5) in the base of the device has to be depressed before applying pressure to the securing brackets (1) (See Fig. 5, right).

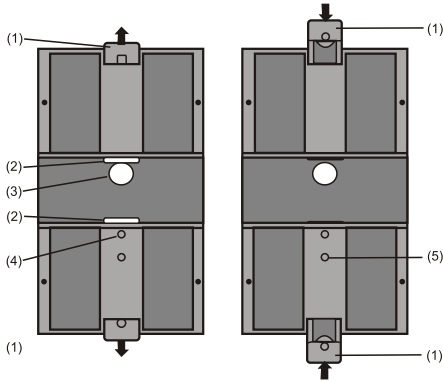

Fig. 5. Rear of device.
 (1) Screw hole brackets
 (2) Top-hat rail clips
 (3) Rubber buffers
 (4) Latch for pulling the screw hole brackets out
 (5) Latch for pushing the screw hole brackets in.

Drill 2 holes in the wall or panel as shown in the drilling pattern (Fig. 6). Now secure the power pack to the wall or panel using two 4 mm diameter screws.

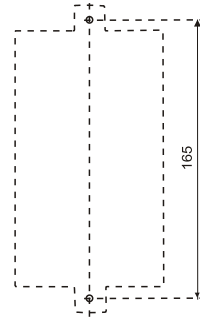

Fig. 6. Drilling plan

5. Electrical connections

The connectors are designed as screw terminals. They are suited for single-wire leads of 4 mm² or multiple-wire leads of 2 × 2.5 mm² cross section.



Make sure that the cables are not live when making the connections !

Connect the leads according to the table.

Function		Connection			
Meas. input 	AC current	IL1	1 / 3		
		IL2	4 / 6		
		IL3	7 / 9		
	AC voltage	UL1	2		
		UL2	5		
		UL3	8		
N	11				
Outputs 	Analogue	Digital	A	+	15
			B	-	16
			C	+	17
			D	-	18
			E	+	19
		F	-	20	
		G	+	21	
		H	-	22	
			+	23	
			-	24	
Power supply 	AC	-	13		
		-	14		
	DC	+	13		
		-	14		

If power supply is taken from the measured voltage internal connections are as follow :

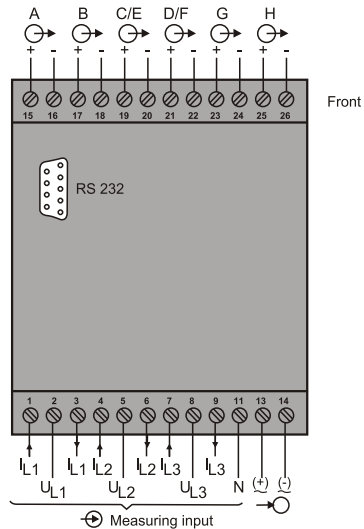

Application (system)	Internal connection Terminal / System
Single phase AC current	2 / 11 (L1 - N)
4-wire 3-phase symmetric load	2 / 11 (L1 - N)
All other (apart from A15/A16/A24)	2 / 5 (L1 - L2)

Measuring inputs

System / application

Terminals

Single-phase AC system

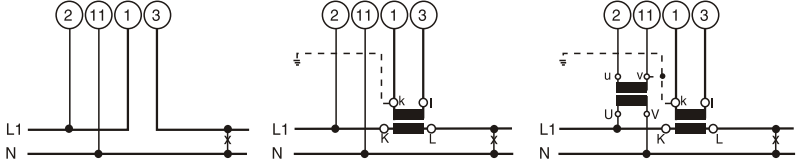

3-wire 3-phase symmetric load
I: L1

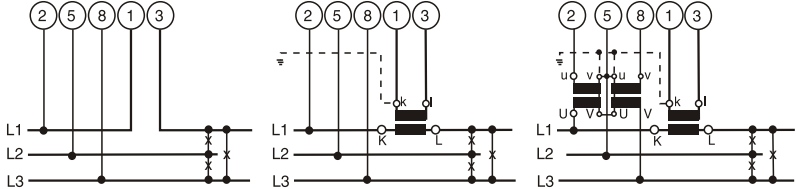

Connect the voltage according to the following table for current measurement in L2 or L3:

Current transf.	Terminals	2	5	8
L2	1 3	L2	L3	L1
L3	1 3	L3	L1	L2

3-wire 3-phase symmetric load
Phase-shift
U: L1 - L2
I: L1

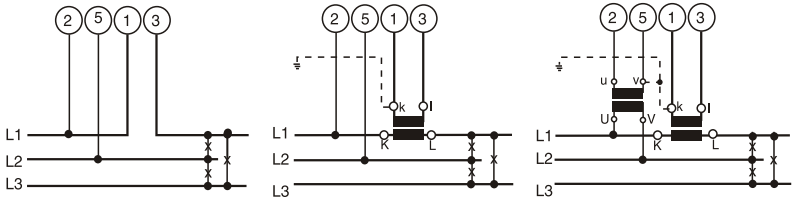

Connect the voltage according to the following table for current measurement in L2 or L3:

Current transf.	Terminals	2	5
L2	1 3	L2	L3
L3	1 3	L3	L1

3-wire 3-phase symmetric load
Phase-shift
U: L3 - L1
I: L1

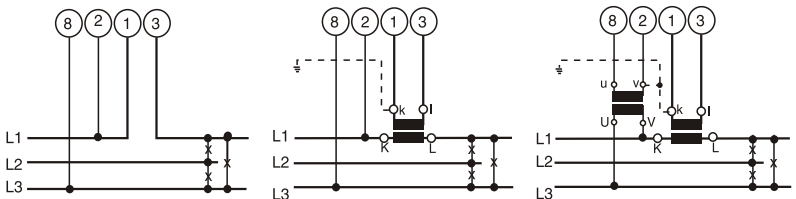

Connect the voltage according to the following table for current measurement in L2 or L3:

Current transf.	Terminals	8	2
L2	1 3	L1	L2
L3	1 3	L2	L3

Measuring inputs

System / application

Terminals

3-wire
3-phase
symmetric
load
Phase-shift
U: L2 - L3
I: L1

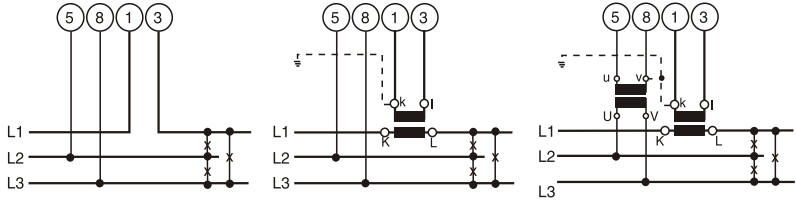

Connect the voltage according to the following table for current measurement in L2 or L3:

Current transf.	Terminals		5	8
L2	1	3	L3	L1
L3	1	3	L1	L2

4-wire
3-phase
symmetric
load
I: L1

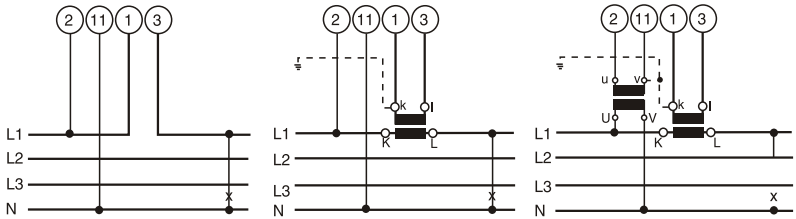

Connect the voltage according to the following table for current measurement in L2 or L3:

Current transf.	Terminals		2	11
L2	1	3	L2	N
L3	1	3	L3	N

3-wire
3-phase
symmetric
load

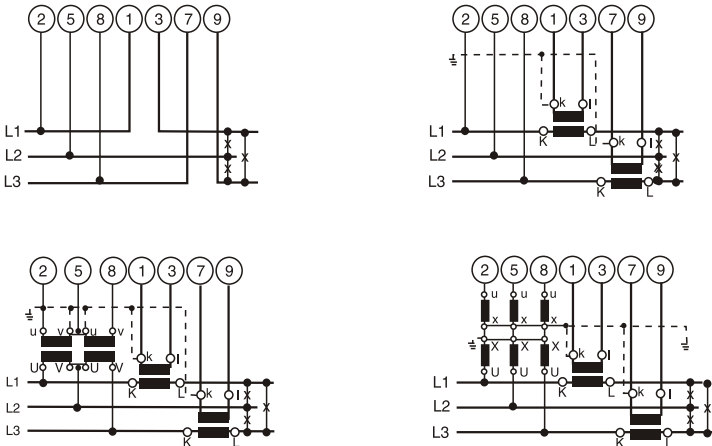

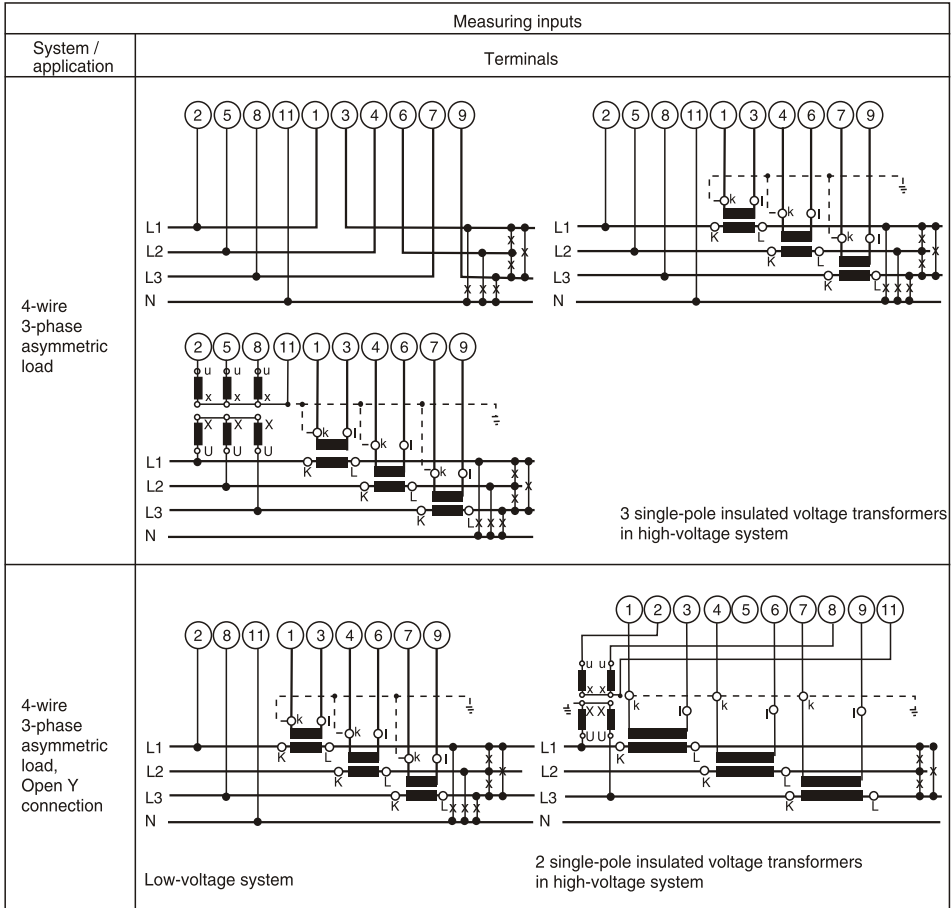

6. Commissioning



Prior to starting, check that the connection data of the transducer agrees with the system data (see type label).

The power supply to the transducer can then be switched on and the signals applied to the measuring inputs.

- | | |
|---|---|
| <ul style="list-style-type: none"> ⊖ Measuring input ⊖ Input voltage ⊖ input current ⊖ Nominal frequency ⊖ System ⊖ Measuring output ⊖ Output signal ⊖ Power supply | <ul style="list-style-type: none"> 6 Manufacturer 8 Conformity marks 9 Terminals Input quantities and power supply 10 Terminals Output quantities |
|---|---|

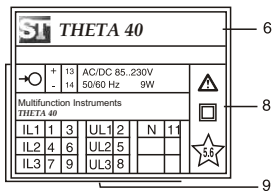

	100V	2A	50Hz	3N-
⊖ A	0.25c	15+	16-	⊖ B 0.25c 17+ 18-
P1	-115.47W	-20mA	P2	-115.47W -20mA
	115.47W	20mA		115.47W 20mA
⊖ E	0.25c	19+	20-	⊖ F 0.25c 21+ 22-
P>	311.77 kW	ON	O>	34.64kvar ON
		Ydel=min		Ydel=min
⊖ G	0.25c	23+	24-	⊖ H 0.25c 25+ 26-
P1>	115.47kW	ON	I1>	2A ON
		Ydel=min		Ydel=min

Fig. 7. Declaration to type label.

6.1 Technical Data

Symbols

Symbols	Meaning
X	Measured variable
X0	Lower limit of the measured variable
X1	Break point of the measured variable
X2	Upper limit of the measured variable
Y	Output variable
Y0	Lower limit of the output variable
Y1	Break point of the output variable
Y2	Upper limit of the output variable
U	Input voltage
Ur	Rated value of the input voltage
U 12	Phase-to-phase voltage L1-L2
U 23	Phase-to-phase voltage L2-L3
U 31	Phase-to-phase voltage L3-L1
U1N	Phase-to-neutral voltage L1-N
U2N	Phase-to-neutral voltage L2-N
U3N	Phase-to-neutral voltage L3-N
UM	Average value of the voltages (U1N + U2N + U3N) / 3
I	Input current
I1	AC current L1
I2	AC current L2
I3	AC current L3
Ir	Rated value of the input current
IM	Average value of the currents (I1 + I2 + I3) / 3
IMS	Average value of the currents and sign of the active power (P)
IB	RMS value of the current with wire setting range (bimetal measuring function)
IBT	Response time for IB
BS	Slave pointer function for the measurement of the RMS value IB
BST	Response time for BS
φ	Phase-shift between current and voltage
F	Frequency of the input variable
Fn	Rated frequency
P	Active power of the system P=P1 + P2 + P3
P1	Active power phase 1 (phase-to-neutral L1 - N)
P2	Active power phase 2 (phase-to-neutral L2 - N)
P3	Active power phase 3 (phase-to-neutral L3 - N)
Q	Reactive power of the system Q = Q1 + Q2 + Q3
Q1	Reactive power phase 2 (phase-to-neutral L1 - N)

Symbols	Meaning
Q2	Reactive power phase 2 (phase-to-neutral L2 - N)
Q3	Reactive power phase 3 (phase-to-neutral L3 - N)
S	Apparent power of the system: $S = \sqrt{I_1^2 + I_2^2 + I_3^2} \cdot \sqrt{U_1^2 + U_2^2 + U_3^2}$
S1	Apparent power phase 1 (phase-to-neutral L1 - N)
S2	Apparent power phase 2 (phase-to-neutral L2 - N)
S3	Apparent power phase 3 (phase-to-neutral L3 - N)
Sr	Rated value of the apparent power of the system
PF	Active power factor $\cos \phi = P/S$
PF1	Active power factor phase 1 P1/S1
PF2	Active power factor phase 2 P2/S2
PF3	Active power factor phase 3 P3/S3
QF	Reactive power factor $\sin \phi = Q/S$
QF1	Reactive power factor phase 1 Q1/S1
QF2	Reactive power factor phase 2 Q2/S2
QF3	Reactive power factor phase 3 Q3/S3
LF	Power factor of the system $LF = \text{sgn}Q \cdot (1 - PF)$
LF1	Power factor phase 1 $\text{sgn}Q1 \cdot (1 - PF1)$
LF2	Power factor phase 2 $\text{sgn}Q2 \cdot (1 - PF2)$
LF3	Power factor phase 3 $\text{sgn}Q3 \cdot (1 - PF3)$
c	Factor for the intrinsic error
R	Output load
Rn	Rated burden
H	Power supply
Hn	Rated value of the power supply
CT	c.t. ratio
VT	v.t. ratio

Input

Waveform:	Sinusoidal
Nominal frequency:	ACC.: o type table
Consumption (at external power supply):	Voltage circuit: $\leq U^2/400$ kΩ Current circuit: 0.3 VA . 1/5 A

Continuous thermal ratings of inputs

Current circuit	10 A 400 V single-phase AC system 693 V three-phase system
Voltage circuit	480 V single-phase AC system 831 V three-phase system

Short-time thermal rating of inputs

Input variable	Number of Inputs	Duration of overloads	Interval between two overloads
Current circuit	400 V single-phase AC system 693 V three-phase system		
100 A	5	3 s	5 min.
250 A	1	1 s	1 hour.
Voltage circuit	1 A, 2 A, 5 A		
Single-phase AC system 600 V $H_{\text{Interm}} : 1.5 \text{ Ur}$	10	10 s	10 s
Three-phase system 1040 V $H_{\text{Interm}} : 1.5 \text{ Ur}$	10	10 s	10 s

Analogue outputs \rightarrow

For the outputs A, B, C and D:

Output variable Y	Impressed DC current	Impressed DC voltage
Full scale Y2	see "Ordering information"	see "Ordering information"
Limits of output signal for input overload and / or $R = 0$ and $R \rightarrow \infty$	$1.25 \cdot Y2$ 30 V	40 mA $1.25 \cdot Y2$
Rated useful range of output load	$0 \leq \frac{7.5 \text{ V}}{Y2} \leq \frac{15 \text{ V}}{Y2}$	$\frac{Y2}{2 \text{ mA}} \leq \frac{Y2}{1 \text{ mA}} \leq \infty$
AC component of output signal (peak-to-peak)	$\leq 0.005 \cdot Y2$	$\leq 0.005 \cdot Y2$

The outputs A, B, C and D may be either short or open circuited. They are electrically insulated from each other and from all other circuits (floating).

Digital outputs, pulse outputs, limit outputs \rightarrow

The digital outputs conform to DIN 43 864. The pulse width can be neither programmed nor is there a hardware setting.

Type of contact : Open collector

Number of pulses : Programmable

Pulse duration : $\geq 100 \text{ ms}$

Interval: $\geq 100 \text{ ms}$

External power supply: 8 ... 40 V

Output current ON 10... 27 mA

OFF $\leq 2 \text{ mA}$

System response

Duration of the measurement cycle: Approx. 0.25 to 0.5 s at 50 Hz, depending on measured variable and programming

Response time: 1 ... 2 times the measurement cycle

Accuracy class (the reference value is the full-scale value Y2)

Measured variable	Condition	Accuracy class*
System: Active, reactive and apparent power	$0.5 \leq X2/Sr \leq 1.5$ $0.3 \leq X2/Sr < 0.5$	0.25 c 0.5 c
Phase: Active, reactive and apparent power	$0.167 \leq X2/Sr \leq 0.5$ $0.1 \leq X2/Sr < 0.167$	0.25 c 0.5 c
Power factor, active power and reactive power	$0.5Sr \leq S \leq 1.5.Sr$, $(X2 - X0) = 2$	0.25 c
	$0.5Sr \leq S \leq 1.5.Sr$, $1 \leq (X2 - X0) < 2$	0.5 c
	$0.5Sr \leq S \leq 1.5.Sr$, $0.5 \leq (X2 - X0) < 1$	1.0 c
	$0.1Sr \leq S < 0.5.Sr$, $(X2 - X0) = 2$	0.5 c
	$0.1Sr \leq S < 0.5.Sr$, $1 \leq (X2 - X0) < 2$	1.0 c
	$0.1Sr \leq S < 0.5.Sr$, $0.5 \leq (X2 - X0) < 1$	2.0 c
AC voltage	$0.1 \text{ Ur} \leq U \leq 1.2 \text{ Ur}$,	0.2 c
AC current / current averages	$0.1 \text{ Ir} \leq I \leq 1.5 \text{ Ur}$,	0.2 c
System frequency	$0.1 \text{ Ur} \leq U \leq 1.2 \text{ Ir}$, resp. $0.1 \text{ Ir} \leq I \leq 1.5 \text{ Ir}$	$0.15 + 0.03 \text{ c}$ ($f_n = 50 \dots 60 \text{ Hz}$) $0.15 + 0.1 \text{ c}$ ($f_n = 16 \text{ 2/3 Hz}$)
Pulse	acc. to IEC 1036 $0.1 \text{ Ir} \leq I \leq 1.5 \text{ Ir}$	1.0

* Basic accuracy 0.5 c for applications with phase-shift

Factor c (the highest value applies):

Linear characteristic:	$c = \frac{1 - \frac{Y_0}{Y_2}}{1 - \frac{X_0}{X_2}}$ or $c = 1$
Bent characteristic: $X_0 \leq X \leq X_1$	$c = \frac{Y_1 - Y_0}{X_1 - X_0} \cdot \frac{X_2}{Y_2}$ or $c = 1$
$X_1 < X \leq X_2$	$c = \frac{1 - \frac{Y_1}{Y_2}}{1 - \frac{X_1}{X_2}}$ or $c = 1$

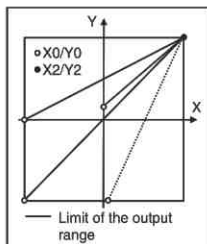

Fig. 8. Examples of settings with linear characteristic.

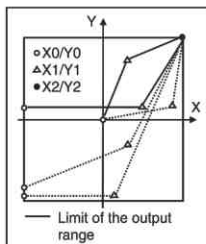

Fig. 9. Examples of settings with bent characteristic.

Influencing quantities and permissible variations

Acc. to DIN IEC 688

Electric safety

Protection class: II
Enclosure protection: IP 40, housing
IP 20, terminals

Overvoltage category: III

Insulation test: Input voltage: AC 400 V
Input current: AC 400 V
Output: DC 40 V
Power supply: AC 400 V, DC 230 V

Power supply →

AC voltage: According to type label

Consumption: ≤ 9 W resp. ≤ 10 VA

Programming connector on transducer

Interface: RS 232 C
DSUB socket: 9-pin.

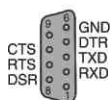

The interface is electrically insulated from all other circuits

Ambient conditions

Climatic rating: Climate class 3 acc. to VDI/VDE 3540
Nominal range of use for temperature: 0... 15... 30... 45°C (usage group II)
Storage temperature: -40 to +85°C
Annual mean relative humidity: ≤ 75%

6.2 Programming the transducer

The Multifunction Instrument *THETA 40* have an integrated RS 232 C interface (SCI).

The existing programming can be matched conveniently to a changed situation and stored via the "Programming software for Multifunction Instrument *M42 / M24*."

For this purpose, the RS 232 output of the transducer must be connected to a PC via the RS 232 C (SCI) programming cable and the transducer must be supplied with power supply.

The programming software has an easy-to-operate, clear menu structure which allows for the following functions to be performed:

- ✦ Reading and displaying the programmed configuration of the transducer
- ✦ Clear presentation of the input and output parameters
- ✦ Transmission of changed programming data to the transducer and for archiving of a file
- ✦ Protection against unauthorized change of the programming by entry of a password
- ✦ Configuration of all the usual methods of connection (types of power system)
- ✦ Easy change of input and output parameters

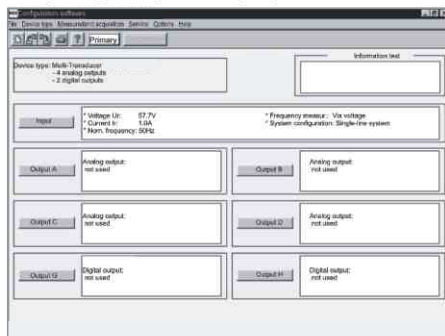

Fig. 10. Presentation of all programming parameters in the main menu.

- ✦ Selection possibility for frequency measurement via voltage or current
- ✦ Possibility to reset the slave pointer of the output quantity involved
- ✦ Parameter setting of outputs A and B resp. A to D (input of measured quantity, upper limits, limitation of upper limits and response time per output)
- ✦ Graphics display of the set system behaviour of each output
- ✦ Recording of measured variables

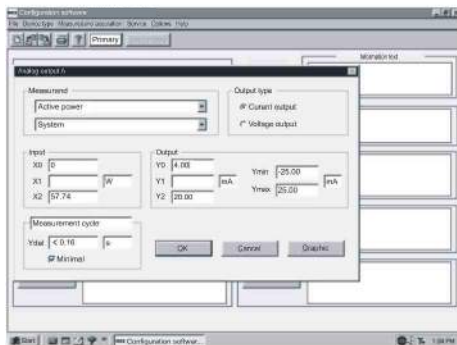

Fig. 11. Programming of the output quantities.

- ✦ Definition of the digital outputs G and H, respectively E to H, either to produce an output impulse (counter impulse) for measuring Ah, Wh, Varh and VAh or to monitor a limit. 2 limit monitor outputs (G and H) permit up to 3 measurements each to be logically interlocked.

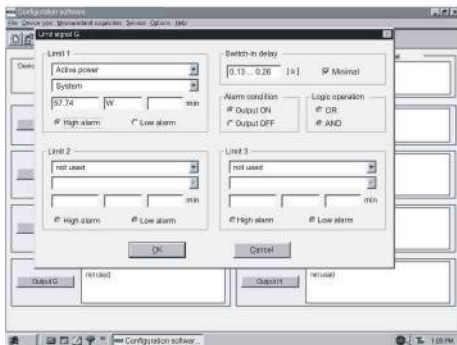

Fig. 12 Assignment of limits to outputs E to H

Provision is also made for the following ancillary functions:

- ✦ The power system check
- ✦ Provision for displaying the measured variably on a PC monitor
- ✦ The simulation of the outputs for test purposes
- ✦ Printing of nameplates

6.3 Operation of the binary outputs

The binary outputs are electrically isolated from all other circuits via an optocoupler.

They therefore require an additional power supply to energise the output circuits.

Outputs \rightarrow E, F, G and H in the case of *THETA 40* and outputs \rightarrow G and H in the case of *THETA 40* are available (see Section "Electrical connections")

External power supply: 8 ... 40 V

Output current ON 10 ... 27 mA

OFF \leq 2 mA

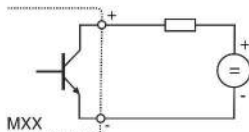

Fig. 13 Block circuit diagram for operation of the binary outputs.

7. Withdrawing and inserting the device

(Fig. 14)

CAUTION! The warranty is void if the device is tampered with!

Remove the locking pins (11) on the rear of the transducer. Screw wood screws of about 2 mm diameter partly in to the locking pin holes and pull them out using small pliers.

Press in the retaining hook (12) with a screwdriver and remove the cover.

To close the device, insert a guide rail into the base of the housing and press the two parts gently together until the hooks engage.

Replace the locking pins.

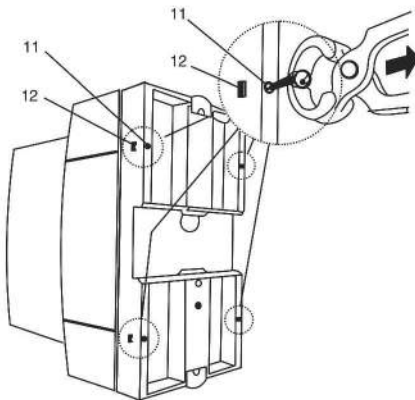

Fig. 14 Withdrawing the device

8. Reconfiguring the analogue outputs

The alternative configurations for the analogue outputs can be seen from Table 1.

Table 1 :

Action	Procedure
Change the current full-scale value from, for example, 20 mA to 10 mA (a hardware setting always has to be made when changing from a lower to a higher value)	Reconfigure the software, but do not change the hardware setting. Accuracy is reduced (see Section 8.1)
	Reconfigure the software, and change the hardware setting. Accuracy is not reduced (see Section 8.2)
Change the current output [mA] to a voltage output [v] or vice versa	Reconfigure the software, change the hardware setting and calibrate the output (see Section 8.2)

Note: In event of No input Voltage applied & only Current input applied, configuring frequency must be via current during input configuration.

8.1 Without hardware setting change

The PC software MXX and a programming cable are needed in order to reprogram the device. The reduced accuracy resulting from this change can be determined by printing a type label (see Fig. 15 and 16)

400kV/400V		1000/1.0A		50Hz		3N~	
↻ A	0.25c	15+	16-	↻ B	0.25c	17+	18-
P	0W	0.0mA		U1N	215V	0.0mA	
	500W	20.0mA			240V	20.0mA	
↻ C	0.25c	19+	20-	↻ D	.15+0.03c	21+	22-
I1	0.000A	0.0mA		F	49.5Hz	0.0mA	
	0.500A	20.0mA			50.5Hz	20.0mA	
↻ G	1.0	23+	24-	↻ H	0.25	25+	26-
P	5000	/ kWh		I1<	0.225A	ON	
□ R				U1N>	233V	Ydel=0s	
				F>	50.0Hz	OR	

Fig. 15. Example of a type label with the present 20 mA output and an accuracy class of 0.25c.

400kV/400V		1000/1.0A		50Hz		3N~	
↻ A	0.45c	15+	16-	↻ B	0.25c	17+	18-
P	0W	0.0mA		U1N	215V	0.0mA	
	500W	10.0mA			240V	20.0mA	
↻ C	0.25c	19+	20-	↻ D	15+0.03c	21+	22-
I1	0.000A	0.0mA		F	49.5Hz	0.0mA	
	0.500A	20.0mA			50.5Hz	20.0mA	
↻ G	1.0	23+	24-	↻ H	0.25	25+	26-
P	5000	/ kWh		I1<	0.225A	ON	
□ R				U1N>	233V	Ydel=0s	
				F>	50.0Hz	OR	

Fig. 16. Example of a type label with the new output of 10mA and an accuracy class of 0.45c.

8.2 With hardware setting change



Unauthorized repair or alteration of the unit invalidates the warranty!

The PC software and a programming cable are needed in order to reprogram the device.

If modifying hardware range limits of analog outputs you have to change resistances on the output PCB. The range limit is realized by means of a resistance, which is separated in two resistances for better accuracy: The resistances must be selected for minimized error. The calculation of this values and the assembling of the other variable components is shown below. However, the consequence of every hardware modification is a new output calibration.

Output calibration

With this function you can perform a new calibration of the analog outputs. You can adjust the outputs to the given facts of subsequent devices as well. However, you have to calibrate every output after changing its hardware to achieve the desired accuracy.

To perform an output calibration you have to connect a voltmeter respectively ammeter of sufficient accuracy to the output terminals. On software demand you have to read measurands and put them to the software. If you adjust the output for subsequent devices, you have to take the measurands from these devices logically. The new calibration data will be stored as customer calibration. Any time you can load the factory calibration separately for each output.

Before performing any output calibration warm up the device to operating temperature first (min. 30 min. acc. fo DIN EN 60 668).

For further informations see PC software for **M42 / M24 "Help"**



To perform an output calibration you have to connect a voltmeter respectively ammeter of sufficient accuracy to the output terminals.

The instructions for opening the device are to be found in Section "7. Withdrawing and inserting the device."

Current output / Voltage output
(Output A : x = 1, Output B : x = 2, Output C : x = 3,
Output D : x = 4)

Variantes

Output	Brx01	Rx43	Rx34	Rx44	Rx45	Rx46
Output mA	Open	0 Ω (950685) or soldered	27kΩ (951360)	Open	Variable	Variable
Output V	sode- red	Open	Variable	Var- iable	0 Ω (950685) or soldered	never mind

The locations of the variable components on the plug-in output board are shown in Figures 17 and 18.

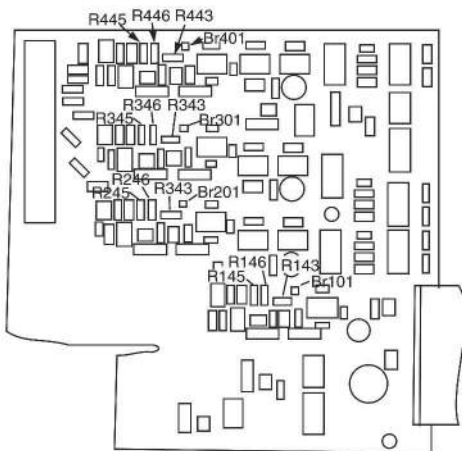

Fig. 17. Top view of the output board

Calculation of resistors Rx45 and Rx46 for the scale output currents Y2 in the range ≥ 1 to ≤ 20 mA:

Current Output				
$Rx45 // Rx46 = \frac{1}{\frac{Y2 \text{ (mA)}}{0.99158 \text{ V}} - \frac{1}{27 \text{ k}\Omega}}$				
Y2	Rx45	Order No.	Rx45	Order No.
20 mA	Open	----	49.9 Ω	102 575
10 mA	Open	----	100 Ω	951 089
5 mA	Open	----	200 Ω	101 717
2.5 mA	2.7 kΩ	951 245	470 Ω	951 162
1 mA	3.3 kΩ	951 253	1.5 kΩ	951 211

Calculation of resistors Rx34 and Rx44 for the full-scale output voltages Y2 in the range ≥ 1 to ≤ 10 V :

Voltage Output				
$Rx34 // Rx44 = Y2 \text{ [V]} - 27 \text{ 229.4}$				
Y2	Rx34	Order No.	Rx44	Order No.
10 V	270 kΩ	951 485	OPEN	----
5 V	270 kΩ	951 485	270 kΩ	951 485
2.5 V	68 kΩ	951 419	OPEN	----
1 V	27 kΩ	951 360	OPEN	----

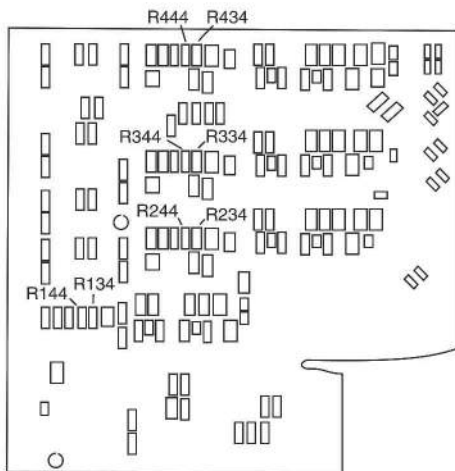

Fig. 18. Bottom view of The output board.

9. Maintenance

No maintenance is required.

10. Releasing the transducer

Release the transducer from a top-hat rail as shown in Fig. 19

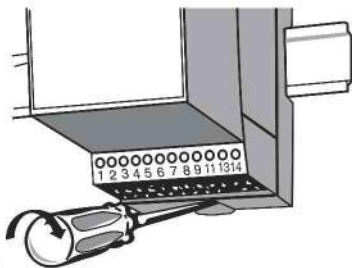

Fig. 19

11. Dimensional drawings

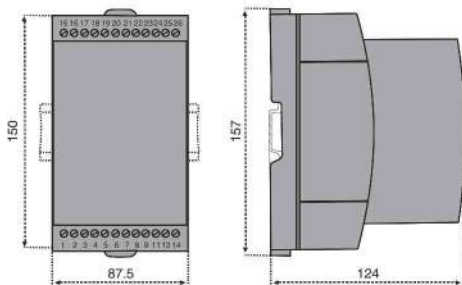

Fig. 20 Multifunction Instrument in housing T24 clipped onto a top-hat rail (35 x 15 mm or 35 x 7.5 mm, acc. to EN 50 022)

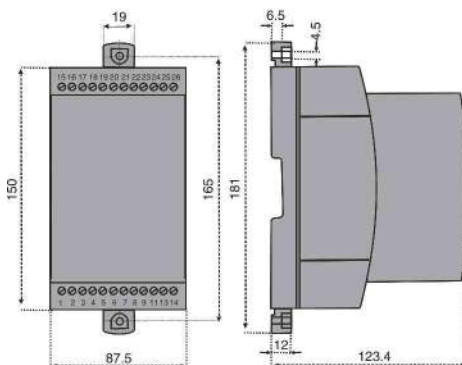

Fig. 21 Multifunction Instrument T24 screw hole mounting brackets pulled out.

12. Safety notes

- Before you start the device check for which power supply it is built.
- Verify that the connection leads are in good condition and that they are electrically dead while wiring the device.
- When it must be assumed that safe operation is no longer possible, take the device out of service (eventually disconnect the power supply and the input voltage!)
This can be assumed on principle when the device shows obvious signs of damage.

The device must only be used again after troubleshooting, repair and a final test of calibration and dielectric strength in our factory or by one of our service facilities.

- When opening the cover, live parts may be exposed. Calibration, maintenance or repair with the device open and live must only be performed by a qualified person who understands the danger involved. Capacitors in the device may still be charged even though the device has been disconnected from all voltage sources.
- After repair on maintenance and closing of the device, the Insulation must be tested with high voltage with the values listed in the technical data.

Meaning of the symbols on the device

The symbols on the device have the following meaning:



Warning of danger
(Caution, see documentation!)



Class II device

NOTE:

flat head lugs with total metal length (J) greater than or equal to 17 mm recommended.

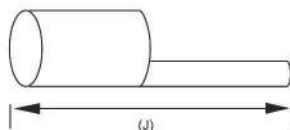

NOTES

WARRANTY

Dear Customer,

You are now the privileged owner of Transducer a product that ranks the first of its kind in the world.

Company provides 12 months warranty from the original date of purchase against defective material and workmanship.

In the unlikely event of failure of this Transducer within the warranty period, Company will repair the Transducer free of charge. Please hand over the Transducer to the dealer / Stockiest from whom you have purchased along with this card and relevant cash memo / Invoice. This warranty entitles you to bring the Transducer at your cost to the nearest stockiest / dealer and collect it after repairs.

NO TRANSPORTATION CHARGES WILL BE REIMBURSED

The warranty is not valid in following cases:

- 1) Warranty card duly signed / stamped and original cash memo / invoice are not sent along with the Transducer .
- 2) Complete warranty card is not presented to authorised person at the time of repairs.
- 3) Transducer not used as per the instruction in the user manual.
- 4) Defect caused by misuse, negligence, accidents, tampering and acts of god.
- 5) Improper repairing by any person not authorised by the company.
- 6) Any sort of modification, alteration is made in electrical circuitry.
- 7) Seal provided inside is broken.

In case of dispute to the validity of warranty, the decision of Company's service center will be final.

If you bought this Transducer directly from the company, and if you notice transit Damage, then you must obtain the insurance surveyors report and forward it to Company.

Thank you.

(To be filled by authorized dealer)

Model No. : _____

Serial Number : _____

Date of Purchase : _____

Cash Memo / Invoice No. : _____

Dealer's Signature : _____

Dealer's Stamp : _____

Scope of Supply:

- 1) Transducer
- 2) Instruction manual
- 3) Test Certificate
- 4) Warranty Card
- 5) RS-232 Interface Cable*
- 6) Software*

* Only with *Theta 40* Transducer



Warning :

Whenever user needs to change the O/P limits without modifying hardware in software there are three options

- No hardware modification (reduced accuracy)
- Modify hardware to new output range limit
- Modify hardware to

Use this option "**No hardware modification (reduced accuracy)**" only.



sifam tinsley
PRECISION INSTRUMENTATION

Manufactured by:

Sifam Tinsley Instrumentation Inc
3105 Creekside Village Dr,
Unit 801, Kennesaw GA 30144

Distributed by:

Veracious Canada Inc
1101 Britannia Rd E,
Mississauga, ON L4W 3X1
Contact: +1 416-640-5364
Fax: +1 416-981-3933
E-mail: info@veraciousinc.ca
Web: www.veraciousinc.com